

Food Grade Pump for Brewing VP60B

Application

- Water Dispenser.
- Coffer maker.
- Hot water heater
- Water Purifying Machine.
- Juice machines.
- Other drinking water equipment.

Feature

- Can endure 100°C high temperature.
- Ceramic sleeve ceramic shaft Long life Low noise. rotation clogging protection .
- Can be customized meet FDA standards .
- Closed impeller, high pressure.
- Lack water protect function.
- PWM/0~5V speed control function [optional]

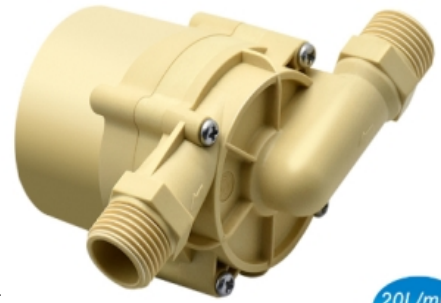

Parameter

Parameter (only for reference, it can be customized)

Model	Voltage V	Rated Current A	Max flow L/MIN	Max head M	Power W
VP60B	12	3	17	8	36
	24	2.2	20	11	53
	48	1.3	21	12	62
	48	1.3	21	12	62

Remarks The parameters above are for reference only, the one based on the customer's endorsement demands shall prevail!

Notice

- Runs in the condition of the pump chamber without liquid is not allowed.
- Reversely connects the power polarity is not allowed.
- Filter measures should be taken when used in foul water environment.
- Runs in the acid and alkali environment is not allowed.
- Ambient temperature and fluid temperature should be within the rated temperature.

Specification

Specs

NO	Items	Specs
1	Sizes	87.2x60.3x108 Weight 0.4kg
2	Dimension of inlet	1/2 inch thread
3	Dimension of outlet	1/2 inch thread
4	Pump material	PPE
5	Condition of use	Continuously
6	Fluids	Water, oil, antifreeze
7	Ambient temperature	-25~70°C
8	Max fluid temperature	0~100°C
9	Power consumption	36W~62W
10	Rated voltage	12V/24V/48V dc
11	Voltage used	8Vdc ~20Vdc, 12Vdc ~ 30Vdc, 36~55Vdc
12	Noise	<45dB
13	Water proof class	IP68
14	Life span	More than 20000hrs
15	Power supply	Solar panel; DC electric source; battery

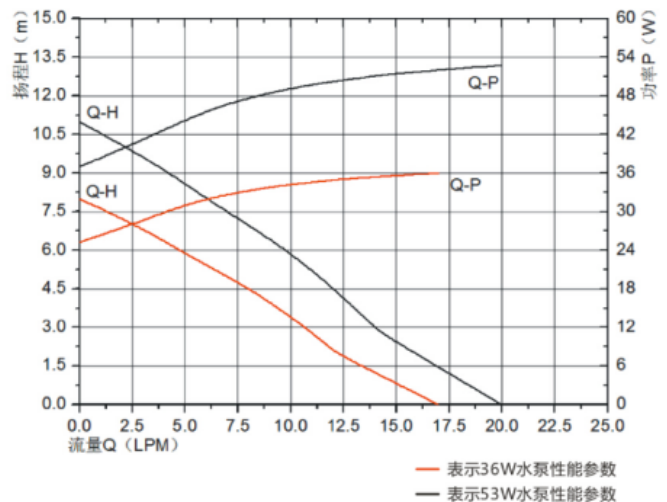
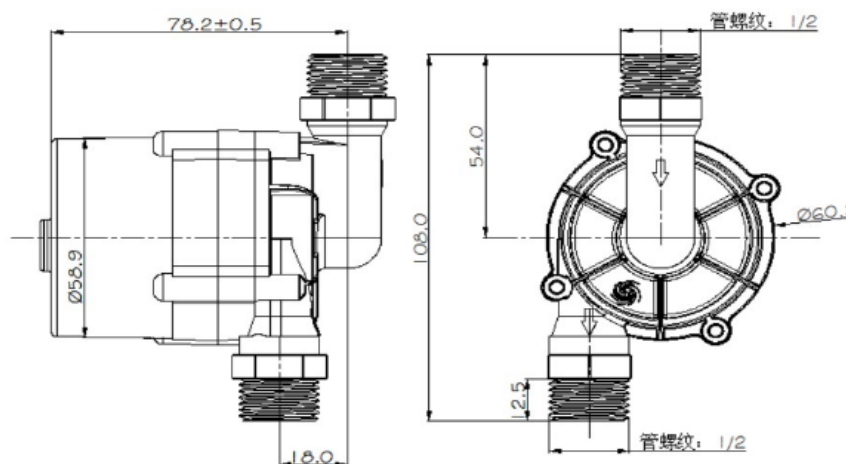

Dimension

Head-Flow curve graph