

# Hot Water Circulation Pump VP50F

## Application

- Water or oil circulation.
- Solar water heater circulation
- Water booster .
- Other water circulation equipment etc.

## Feature

- small size with high efficiency,maintenance-free
- Brush-less dc control without pollution, long life span
- OEM and ODM service accept.
- Offer Pump related control system design.



## Parameter

Parameter (only for reference, it can be customized)

Model	Voltage V	Rated Current A	Max flow L/MIN	Max head M	Power W
VP50F	12	3.8	16.6	6	45.6
	12	3.8	16.6	6	45.6
	24	3.5	25	13	84

Remarks: The parameters above are for reference only, the one based on the customer's endorsement demands shall prevail!

## Specification

NO	Items	Specs
1	Sizes	114.5mm*108mm*71.6mm; weight 650g
2	Dimension of inlet	Thread nozzles: G1/2
3	Dimension of outlet	Thread nozzles: G1/2
4	Pump material	PA66+30%GF
5	Condition of use	Continuously
6	Fluids	Water, oil [Provide acid and alkali solution]
7	Ambient temperature	-10~100°C
8	Max fluid temperature	100°C
9	Power consumption	45.5W~84W(can be customized within this range)
10	Rated voltage	12Vdc,24Vdc
11	Voltage used	6Vdc ~ 14Vdc,10Vdc ~ 24Vdc
12	Noise	<40dB
13	Water proof class	IP68(Submersible installed optional)
14	Life span	More than 30000hrs
15	Power supply	Solar panel; DC electric source; battery

## Notice

- Runs in the condition of the pump chamber without liquid is not allowed.
- Reversely connects the power polarity is not allowed.
- Filter measures should be taken when used in foul water environment.
- Runs in the acid and alkali environment is not allowed.
- Ambient temperature and fluid temperature should be within the rated temperature.
- Only DC power can be used.

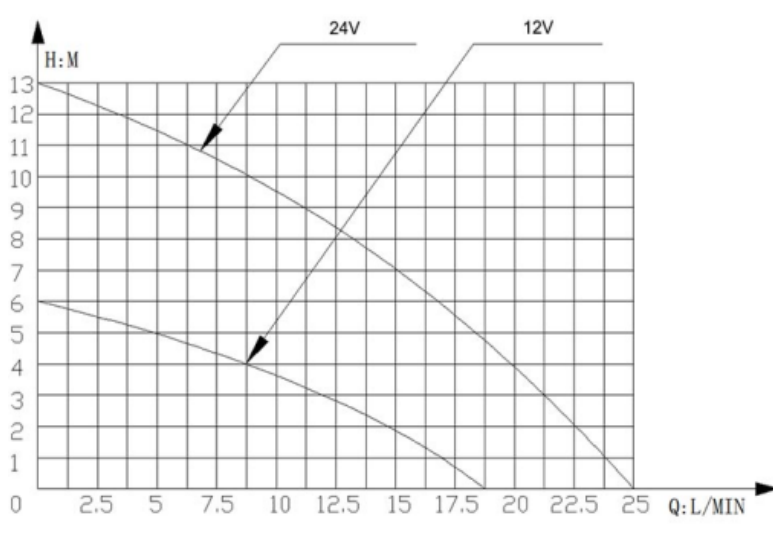
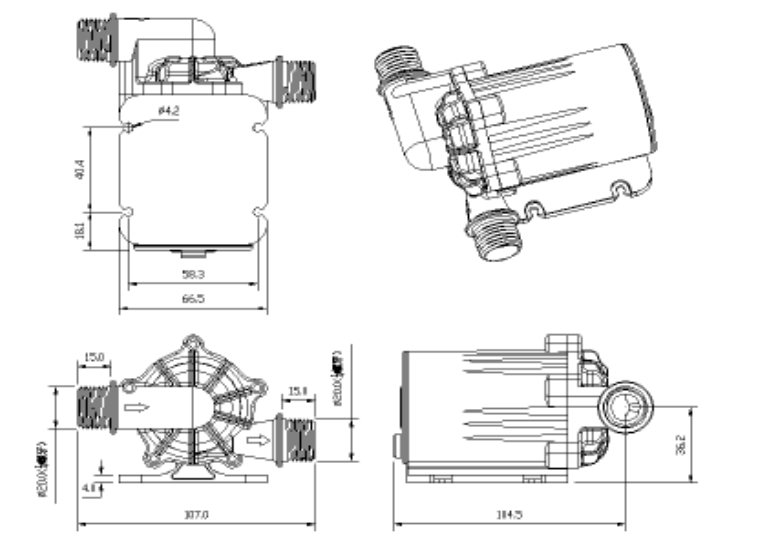

Dimension

Head-Flow curve graph